

CBX

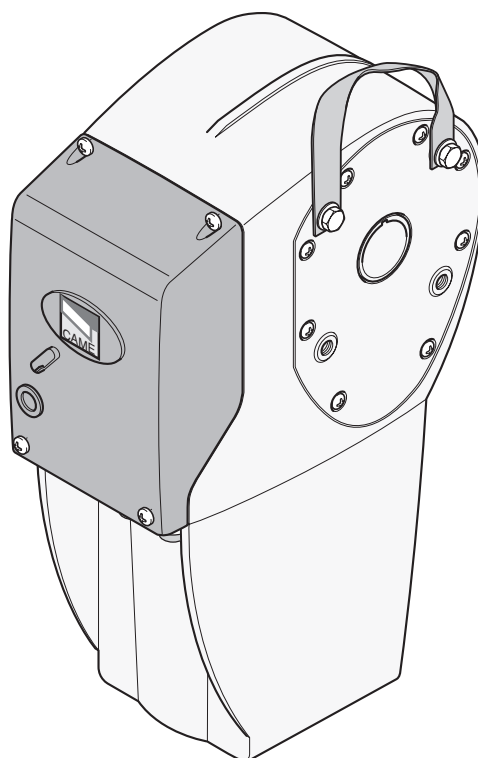

"IMPORTANT SAFETY INSTRUCTIONS FOR INSTALLATION"

"CAUTION: IMPROPER INSTALLATION MAY CAUSE SERIOUS DAMAGE, FOLLOW ALL INSTALLATION INSTRUCTIONS CAREFULLY"

"THIS MANUAL IS ONLY FOR PROFESSIONAL INSTALLERS OR QUALIFIED PERSONS"

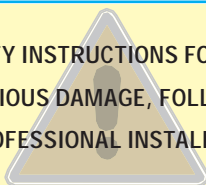

1 Legend

 This symbol indicates sections to be read with particular care.

 This symbol indicates sections concerning safety

 This symbol indicates notes to communicate to users.

2 Destination and use applications

2.1 Destination

The CBX series gearmotor was designed to automate chiefly sectional doors with direct transmission on the shaft using springs or with chain drive; however, the CBX can also be used for sliding and folding doors with the respective accessories.

 Uses other than the ones described above and installations using methods other than those shown in this technical manual are considered prohibited.

2.2 Use applications

For sectional doors with direct transmission: door height up to 5.5 m;
Speed* 7.15 m/1' with cable winder drum ~Ø 105 mm;
Speed* 9.3 m/1' with cable winder drum ~Ø 138 mm.

For sectional doors with chain drive: door height up to 8.5 m;
Speed* 9.15 m/1' with cable winder drum ~Ø 208 mm.

For sliding and folding doors: door width up to 5.5 m for C-BXE / C-BXE24 / C-BXET;
door width up to 11 m for C-BX / C-BXT.
wing weight 1000 kg max.

* The speed varies depending on the diameter of the drum; in particular, models of cable winder drums used by the main sectional door manufacturers in the specific dimensions were inserted into the descriptions.

2.3 Fields of use

C-BX / C-BXE	Residential - Condominium - Industrial
C-BXE24	Residential - Condominium
C-BXT / C-BXET	Industrial

3 Standard followed

The following standard were complied with for this product: EN 12978, UNI EN 954-1, CEI EN 60335-1, UNI EN 12453.

4 Description

4.1 Gearmotor

All gearmotors are designed and built by CAME CANCELLI AUTOMATICI S.p.A. in compliance with the prevailing safety regulations. Guaranteed for 24 months unless tampered with.

The enclosure is made up of a part in aluminium alloy inside of which the non-reversible, electromechanical gearmotor operates, and partly in ABS plastic that houses the terminals for the electrical wiring.

The CBX series has several versions depending on the type of use - residential, condominium or industrial - with mechanical end stop or with an encoder system (see para. 2.3 Fields of use).

The complete line:

Gearmotor 230V A.C. with encoder and control boards

001C-BXE Gearmotor 230V A.C. with encoder

002 ZCX10 - Control board

002 ZCX10C - Control board with safety block and command buttons

Gearmotor 24V A.C. with encoder and control boards

001C-BXE Gearmotor 24V A.C. with encoder

002 ZL80 -Control board

002 ZCX80C - Control board with safety block and command buttons

002 BN1 - Board for connecting 2 emergency batteries (12V - 1.2Ah)

All the data and information contained herein is considered subject to change at any time and at our discretion

Gearmotor 230V / 400V three-phase with encoder and control boards

001C-BXET - Gearmotor 230V/400V A.C. with encoder

002 ZT5 - Control board

002 ZT5C - Control board with safety block and command buttons

Gearmotor 230V A.C. with mechanical end-stop and control boards

001C-BX - Gearmotor 230V A.C. with mechanical end-stop

002 ZC3 - Control board

002 ZC3C - Control board with safety block and command buttons

Containers and electrical cards for gearmotors 230V

001S4339 - Container

001S4339C - Container with safety release and command buttons

001S4340 - Container

001S4340C - Container with safety release and command buttons

003 ZC5 - Basic electrical card

003 ZM2 - Multi-function electrical card

Gearmotor 230/400V three-phase with mechanical end-stop and control boards

001C-BXT - Gearmotor 230V/400V A.C. three phase with mechanical end-stop

002 ZT6 - Control board

002 ZT6C - Control board with safety block and command buttons

The CBX series comes with the following complementary accessories:

001 CMS - Release handle with personalized key and return cord (7 m long);

001 CGP - Chain guide with protective guard for industrial doors;

009 CCT - Simple 1/2" chain for sliding or folding doors;

009 CGIU - Coupling for 1/2" chain;

001 C001 - Winch for manually moving sectional doors;

001 C002 - Pendulum release system;

001 C003 - Chain tightener transmission system and brackets for sliding doors;

001 C004 - Chain tightener transmission system and brackets for folding doors;

001 C005 - Chain drive system for sectional doors with heights over 5.5 m;

001 C006 - Package of two brackets for sectional doors (specific for direct transmission applications);

001 C007/8 - Adapter for sectional doors con \varnothing 25 mm post (C007) or \varnothing 40 mm post (C008);

Important! Make sure that the control and safety equipment and accessories are CAME original. Only CAME products are guaranteed to make the system easy to use and maintain.

4.2 Parts description

GEARMOTOR UNIT

1 - Gearmotor

2 - Release handle

3 - Lower cap

4 - Protection cover

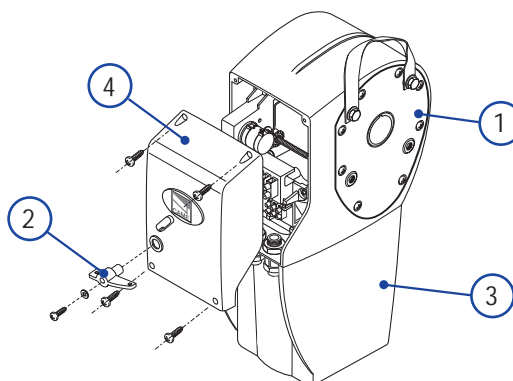

ACCESSORIES

1 - C001 - Winch for manually moving sectional doors

2 - C002 - Pendulum release system

3 - C003 - Chain tightener transmission system and brackets for sliding doors

4 - C004 - Chain tightener transmission system and brackets for folding doors

5 - C005 - Chain drive system for sectional doors

6 - C006 - Package of two brackets for sectional doors

7 - C007/8 - Adapter for sectional doors

8 - CMS - Release handle with personalized key

9 - CGP - Chain guide with protective guard

10 - CCT - Simple 1/2" chain

11 - CGIU - Coupling for 1/2" chain

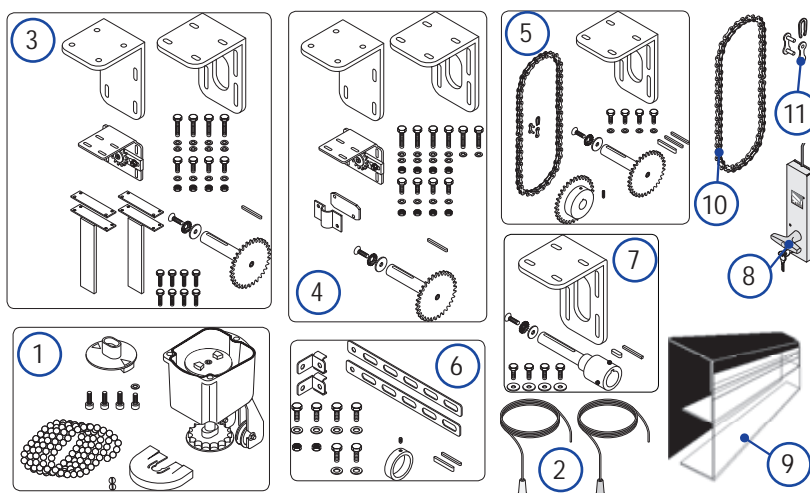

4.3 Technical information

C-BX / C-BXE GEARMOTOR

Power supply panel: 230V A.C. 50/60Hz
 Motor power supply: 230V A.C. 50/60Hz
 Absorption*: 3A
 Rated power*: 450W
 Max. torque*: 60 Nm
 Reduction ratio: 1/67,45
 Drive shaft revolutions: 34(CBX)/20,5(CBXE)
 Motor revolution speed: 21,5 rpm
 Operative intermittence: 30%
 Protection level: IP54
 Weight: 15 kg
 Working time: 

C-BXE24 GEARMOTOR

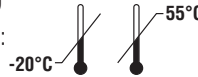
Power supply panel: 230V A.C. 50/60Hz
 Motor power supply: 24V D.C.
 Absorption*: 9A max.
 Rated power*: 240W
 Max. torque*: 25 Nm
 Reduction ratio: 1/67,45
 Drive shaft revolutions: 20,5
 Motor revolution speed: 26,5 rpm
 Operative intermittence: intensive service
 Protection level: IP54
 Weight: 15 kg
 Working time: 

C-BXT / C-BXET GEARMOTOR

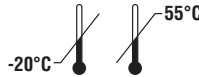
Power supply panel: 230-400V A.C. - 50/60Hz
 Motor power supply: 230-400V A.C.-50/60Hz
 Absorption*: 2,5A
 Rated power*: 780W
 Max. torque*: 80 Nm
 Reduction ratio: 1/67,45
 Drive shaft revolutions: 34(CBXT)/20,5(CBXET)
 Motor revolution speed: 21,5 rpm
 Operative intermittence: intensive service
 Protection level: IP54
 Weight: 15 kg
 Working time: 

* Values relating to the designated electrical board

4.4 Size measurements

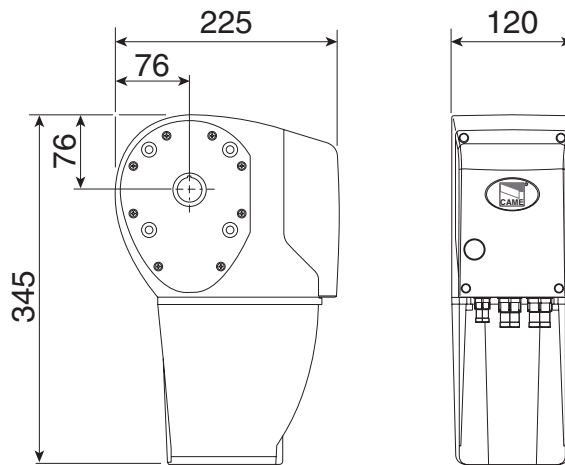

Measurements in mm

5 Installation

 Installation must be carried out by expert qualified personnel and in full observance of regulations in force.

5.1 Preliminary checks

 Before proceeding with the installation, it is necessary to:

- The gearmotor must be installed in an area protected from shocks; the anchoring surface must be solid; and appropriate parts (screws, plugs, etc) must be used to anchor the gearmotor to the surface;
- Provide for suitable omnipolar disconnection device with more than 3 mm between contacts to section power supply.
-  Connections inside the case made for protection circuit continuity are allowed as long as they include additional insulation with respect to other internal drive parts.
- Install suitable tubes and ducts for electric cable passage to guarantee protection against mechanical damage.
- The structure of the door must be sufficiently sturdy, the hinges must be efficient and there must be no friction between fixed or mobile parts;
- Check the presence of a mechanical end-stop during opening and closing.

SECTIONAL DOORS

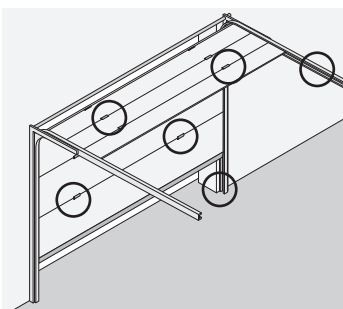

SLIDING DOORS

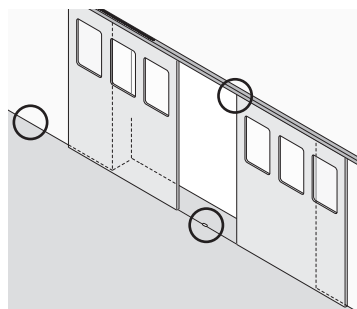

FOLDING DOORS

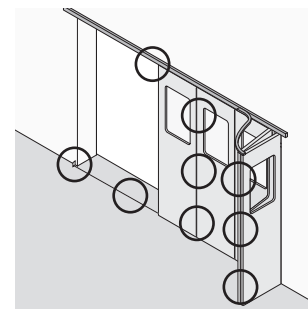

All the data and information contained herein is considered subject to change at any time and at our discretion

5.2 Tools and materials

Make sure all tools and materials necessary are within reach to install the edge in maximum safety, according to regulations in force. The following figure illustrates the minimum equipment for the installer.

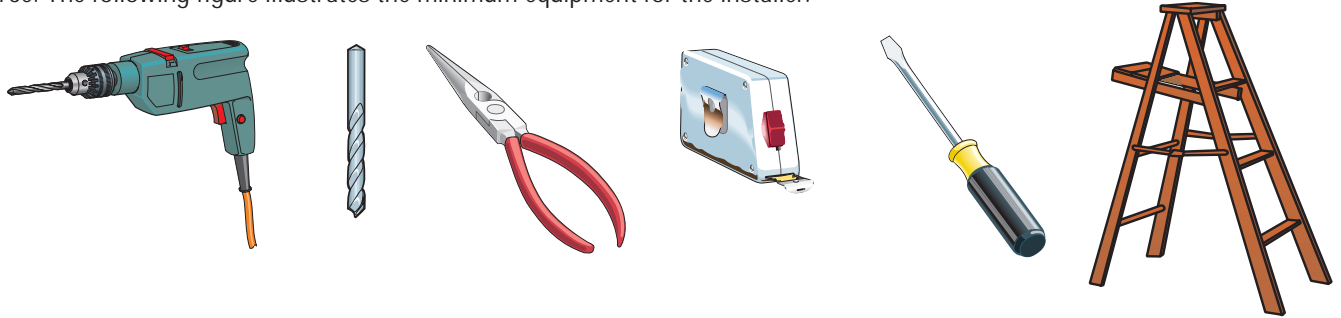

5.3 Cable list and minimum thickness

Connections	Type of cable	Length of cable 1 < 10 m	Length cable 10 < 20 m	Length cable 20 < 30 m
230/400V 3F power supply	FROR CEI 20-22 CEI EN 50267-2-1	4G x 1,5 mm ²	4G x 2,5 mm ²	4G x 4 mm ²
230V 2F power supply		3G x 1,5 mm ²	3G x 2,5 mm ²	3G x 4 mm ²
230/400V 2F/3F power supply motor		4G x 1,5 mm ²	4G x 1,5 mm ²	4G x 1,5 mm ²
24V power supply motor		2 x 1 mm ²	2 x 1,5 mm ²	2 x 2,5 mm ²
24V - 230V flashing lamp		2 x 0,5 mm ²	2 x 1 mm ²	2 x 1,5 mm ²
Photoelectric TX		2 x 0,5 mm ²	2 x 0,5 mm ²	2 x 0,5 mm ²
Photoelectric RX		4 x 0,5 mm ²	4 x 0,5 mm ²	4 x 0,5 mm ²
24V power supply accessory		2 x 0,5 mm ²	2 x 0,5 mm ²	2 x 1 mm ²
Control button		2 x 0,5 mm ²	2 x 0,5 mm ²	2 x 0,5 mm ²
End stop		3 x 0,5 mm ²	3 x 1 mm ²	3 x 1,5 mm ²
Encoder connection	2402C 22AWG	max. 30 m		
Antenna connection	RG58	max. 50 m		

N.B.: An evaluation of the size of the cables with lengths other than the data in the table must be made based on the effective absorption of the connected devices, according to the instructions indicated by the CEI EN 60204-1 standards.

For connections that require several loads on the same line (sequential), the size given on the table must be re-evaluated based on actual absorption and distances.

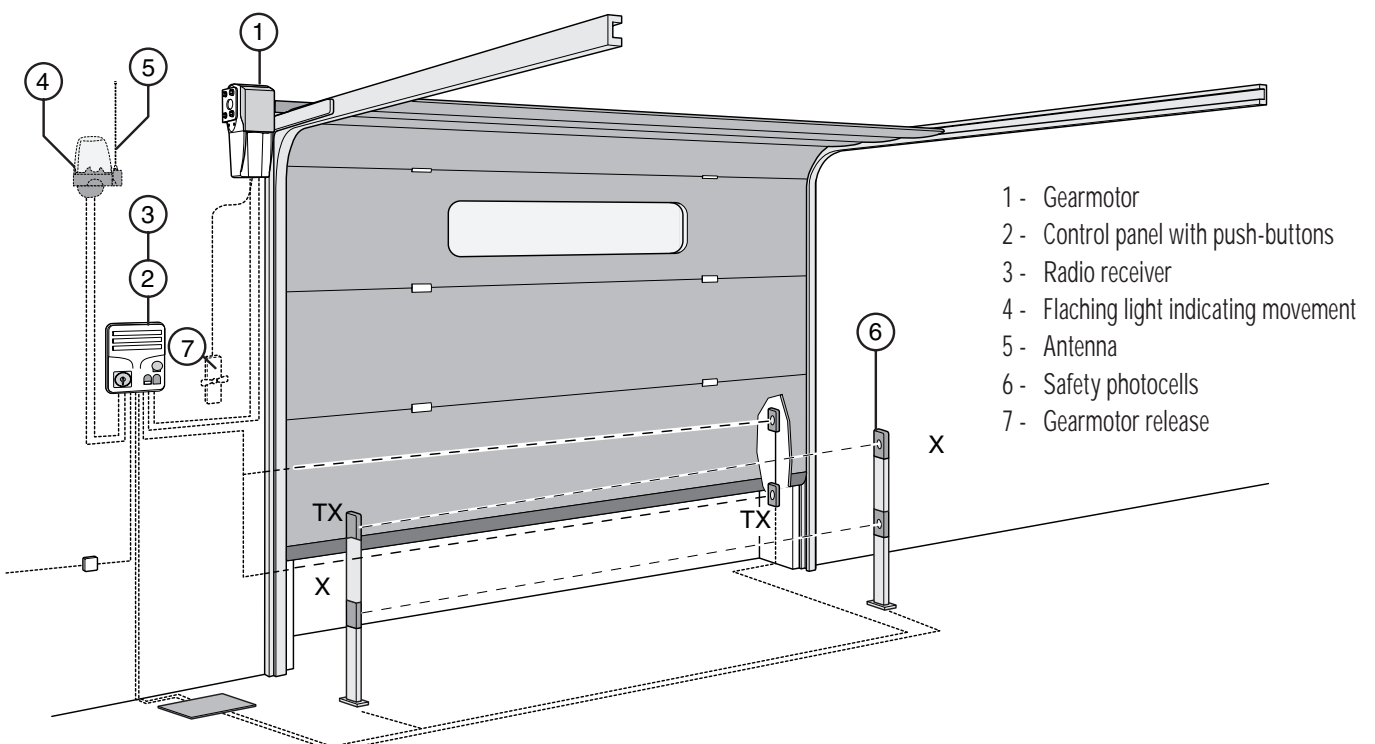

5.4 Installing the automation on sectional doors

⚠ The following applications are only examples, as the space for installing the ratiomotor and accessories varies according to obstructions. It is thus up to the system installer to select the most suitable solution.

DIRECT TRANSMISSION - The CBX ratiomotor is supplied ready for installation with a direct action on the door springs shaft, with a shaft diameter of 1 inch (fig. 1); for special volume requirements, it is also possible to install it horizontally (fig. 2) but for both cases use accessory (Art. C006).

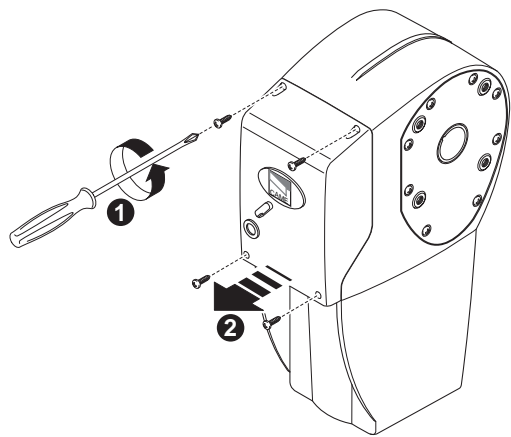
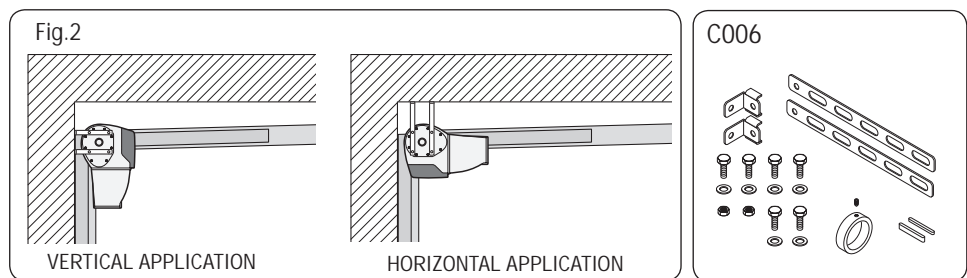
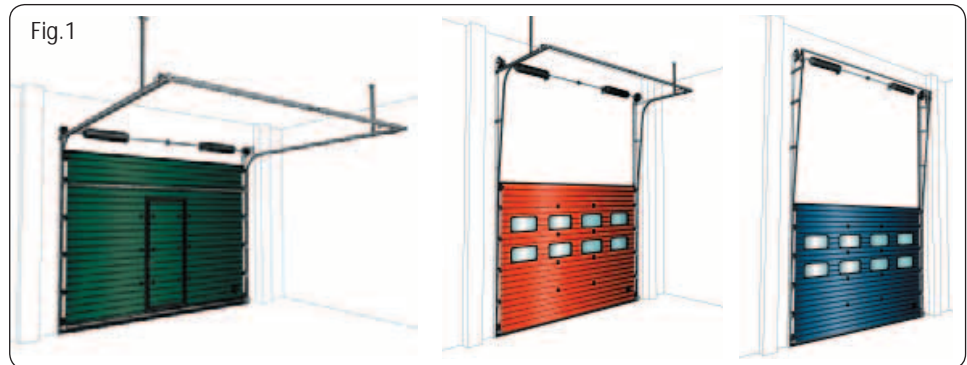

1) Before securing the ratiomotor, open the protection cover to facilitate post-assembly operations.

2) Insert the ratiomotor on the spring pole using the handle on the ratiomotor.

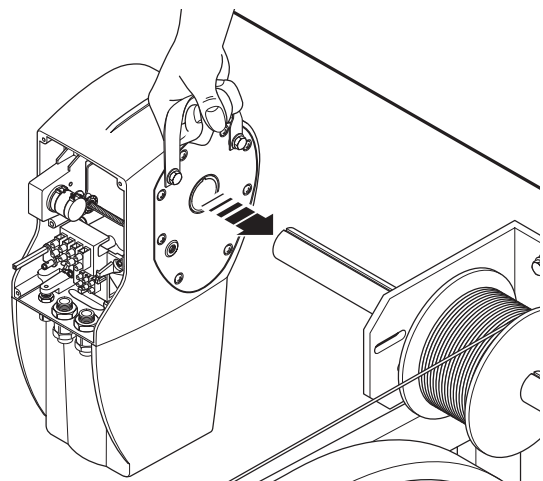

All the data and information contained herein is considered subject to change at any time and at our discretion

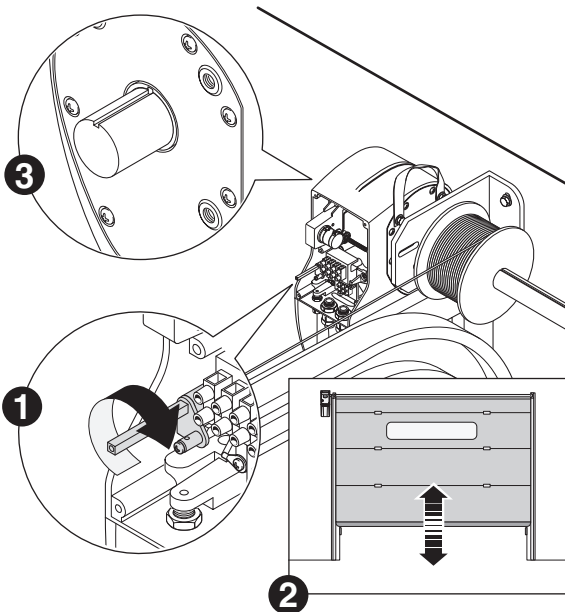

3) Manually release the ratiomotor by turning the rod clockwise and move the door to make the pole cavity coincide with that of the ratiomotor's cable shaft.

4) Insert tongue A or B depending on the type of shaft (see fig. 3) between the two cavities, insert the bushing on the pole and secure with the grub screw.

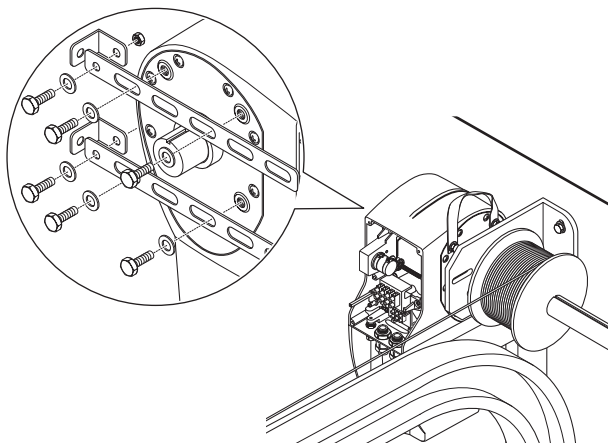
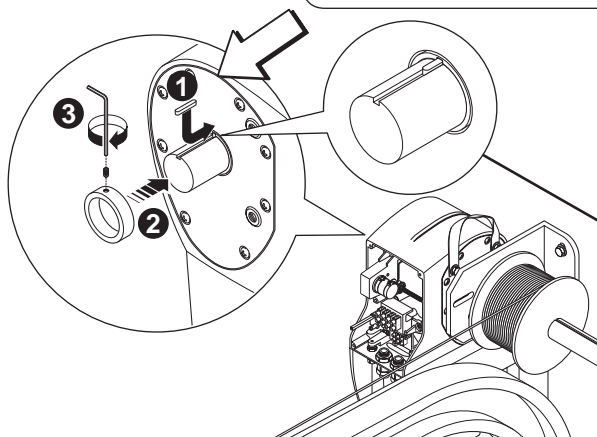
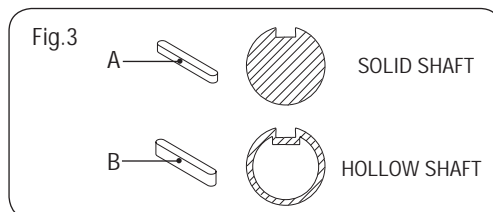

5) Assemble the brackets (Art. C006) and secure them (avoiding blocking them) to the ratiomotor with the supplied screws.

6) Secure the brackets on the wall with suitable screws chosen according to the shape of the wall to secure the brackets onto the ratiomotor.

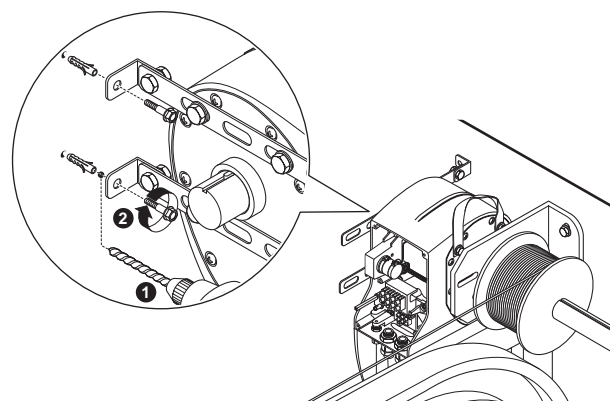

CHAIN TRANSMISSION

- Installations on sectional doors higher than 5.5 m, for this type of application you must use the accessory (Art. C005).

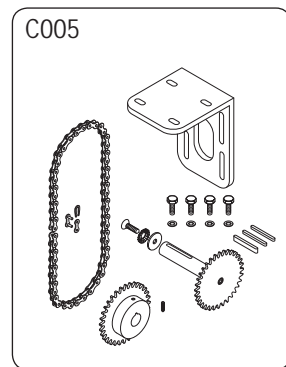
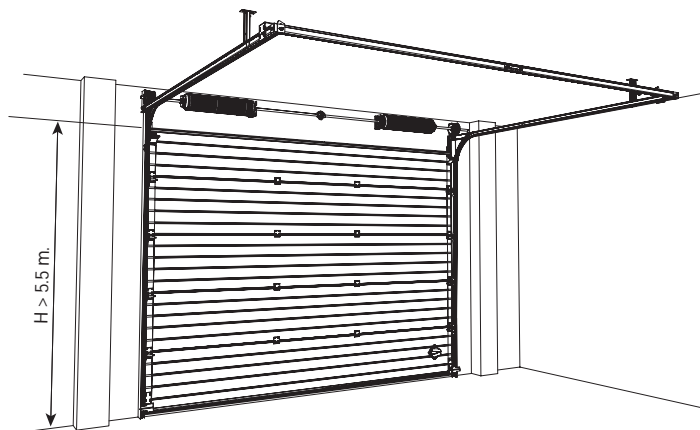

1) Before securing the ratiomotor, open the protection cover to facilitate post-assembly operations.

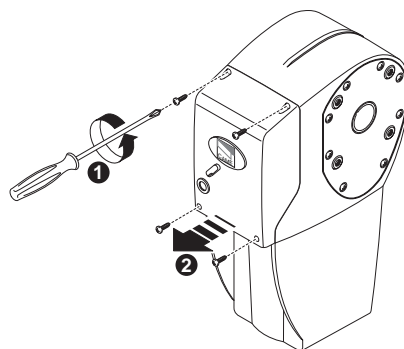

2) Insert tongue A or B (see fig.1) into the cavity of the sprung pole, then insert toothed crown Z40 onto the pole opposite the tongue and secure it with the grub screw.

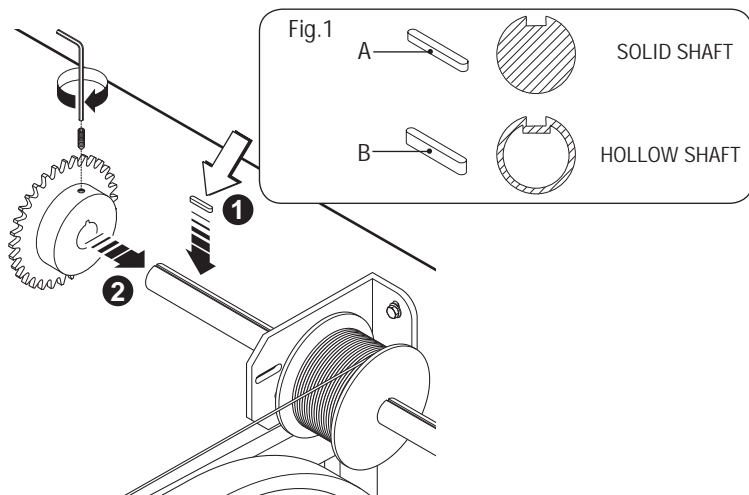

3) Insert tongue A into the cavity of the pinion toothed sprocket shaft Z26, insert the pinion, into the motor cable shaft and secure it with a screw UNI 5933 M6x16 and washer from the opposite side.

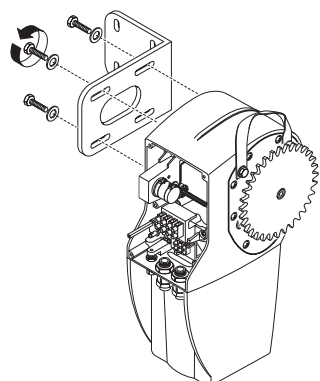
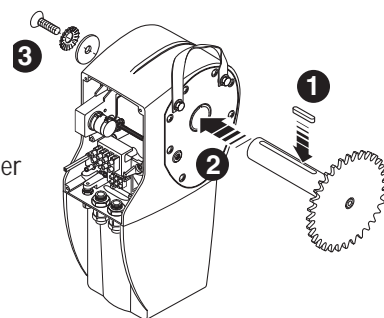

4) Secure the fixing bracket to the ratiomotor with the supplied screws.

All the data and information contained herein is considered subject to change at any time and at our discretion

5) Unite the two ends of the chain with the coupling and insert it onto the toothed crown Z40 leaving it hanging.

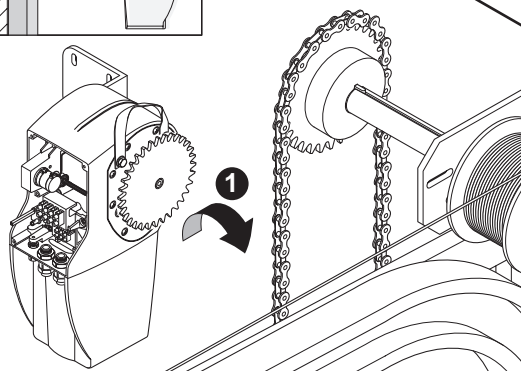
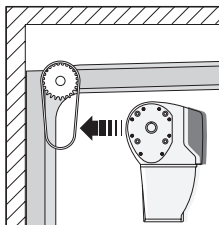
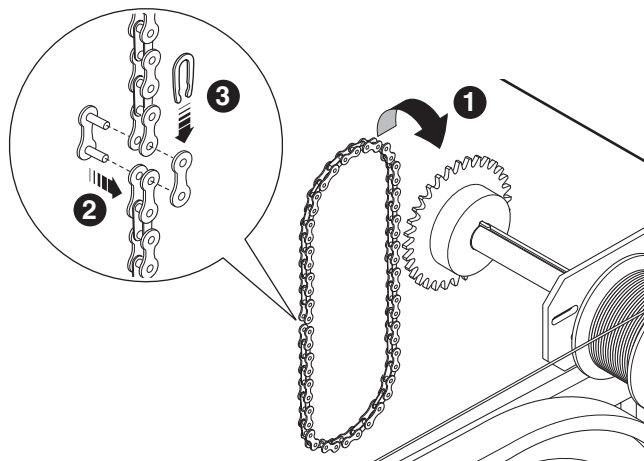

6) Anchor the ratiomotor's shaft pinion to the hanging chain.

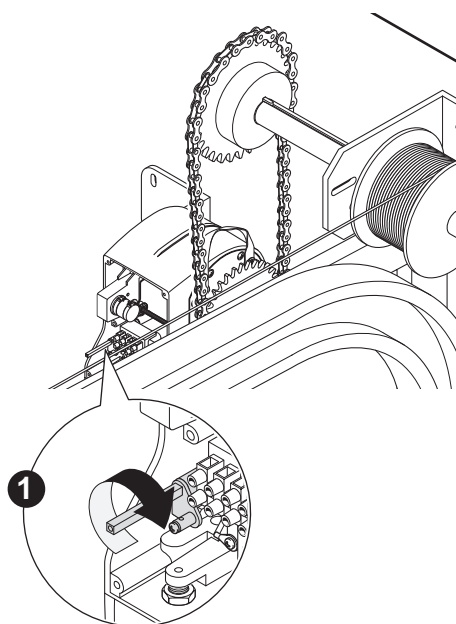

7) Release the ratiomotor by hand by turning the rod clockwise.

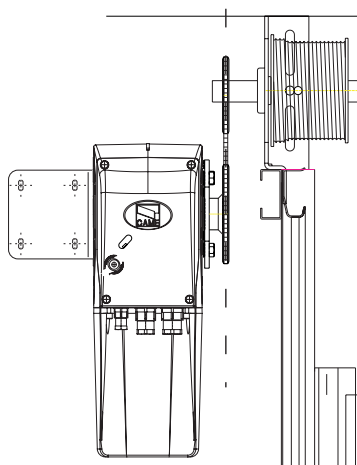

8) Then secure the ratiomotor's fixing bracket with appropriate screws chosen according to the shape on the wall, being sure that the two toothed crowns are perpendicular to each other.

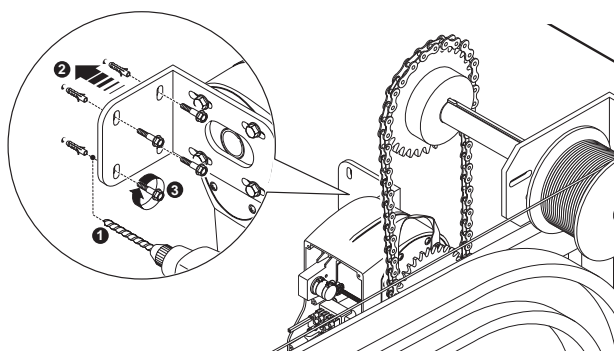

All the data and information contained herein is considered subject to change at any time and at our discretion

5.5 Installing the automation on sliding doors

DOORS WITH ONE OR TWO WINGS - For installations with sliding gates/doors having one or two wings, you must use the accessory C003 (transmission system for sliding gates).

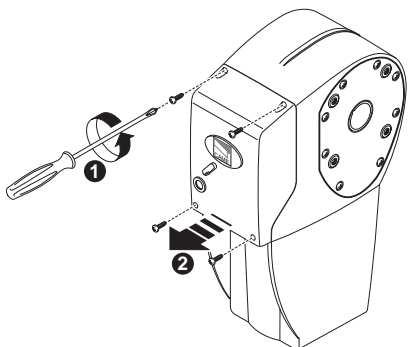
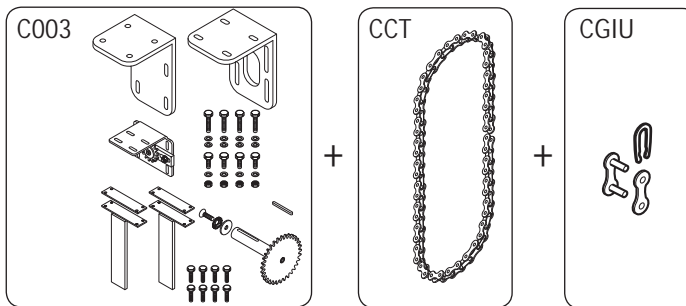

1) Before securing the ratiomotor, open the protection cover to facilitate post-assembly operations.

2) Assemble the two fixing brackets and secure them to the ratiomotor.

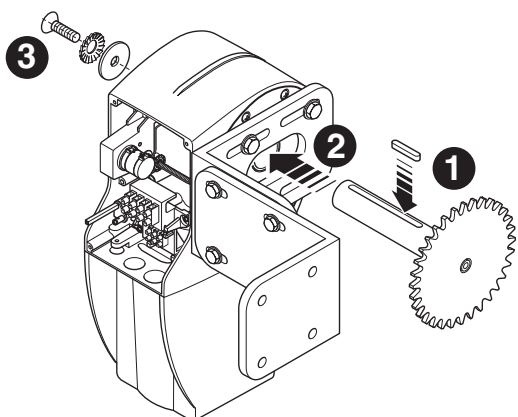
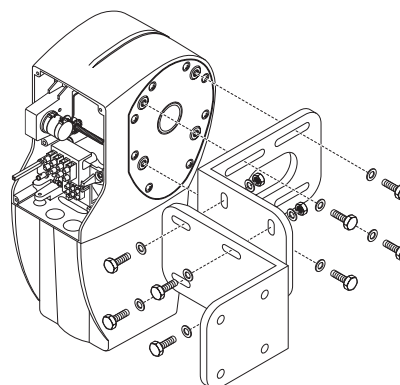

3) Insert the tongue into the cavity of the toothed pinion's shaft Z26, insert the pinion into the motor cable shaft and secure it with a screw (UNI 5933 M6x16) and washer from the opposite side.

4) Secure the assembly above to the right or left of the door using suitable items chosen according to the wall's shape.

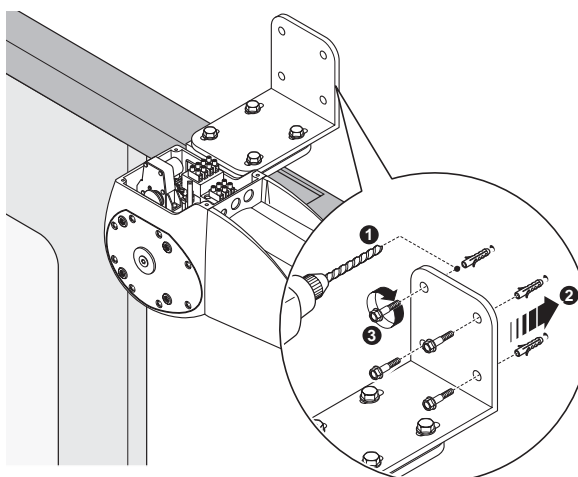

All the data and information contained herein is considered subject to change at any time and at our discretion

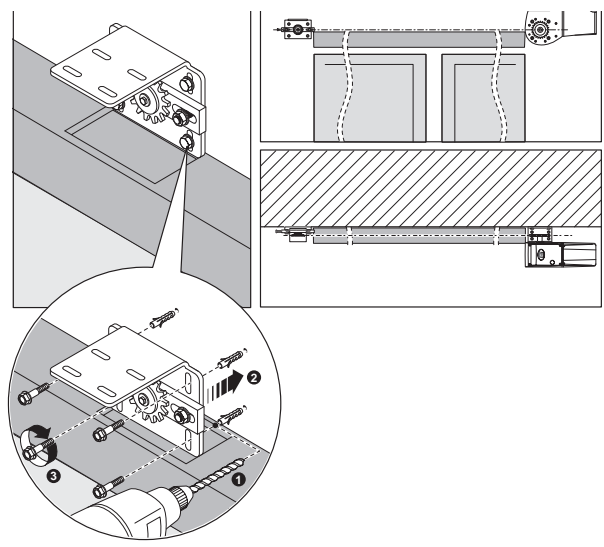

5) Secure the chain-tensioning transmission from the opposite side of the ratiomotor, in line with the pinion.

6) Insert the 1/2 inch chain (CCT) with a length of twice distance A.

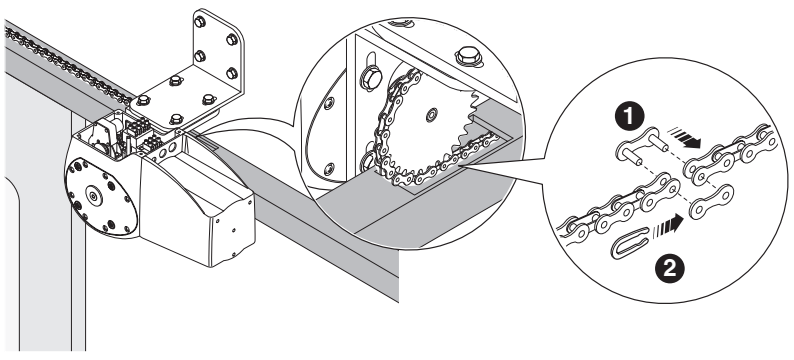
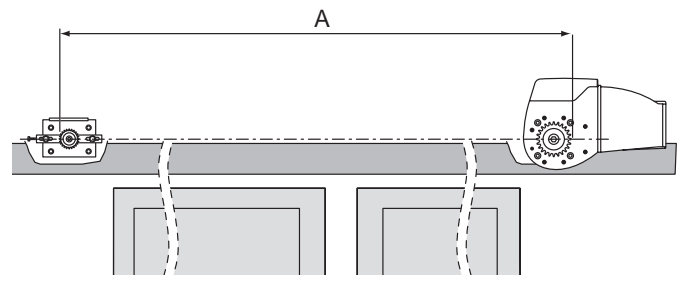

7) Unite the two ends with a coupling (CGIU).

8) Adjust the chain's tension with the transmission's screw and then tighten the nuts.

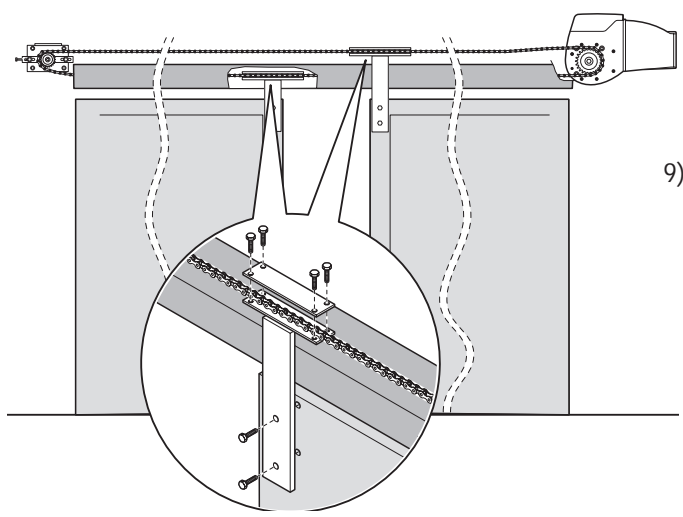
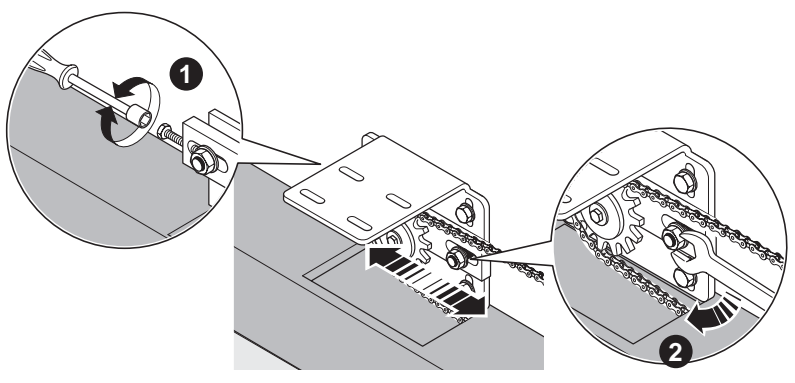

9) Secure the appropriate attachments (brackets and plates) first to the chain and then to the wings.

FOLDING DOORS - For installations with doors having more than one wing, you must use accessory C004 (transmission system for folding doors).

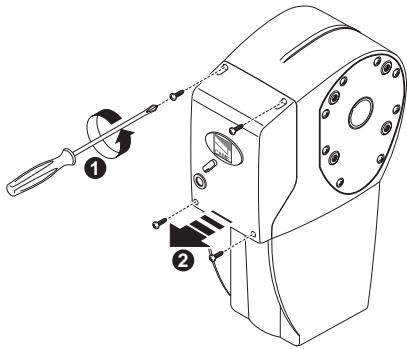
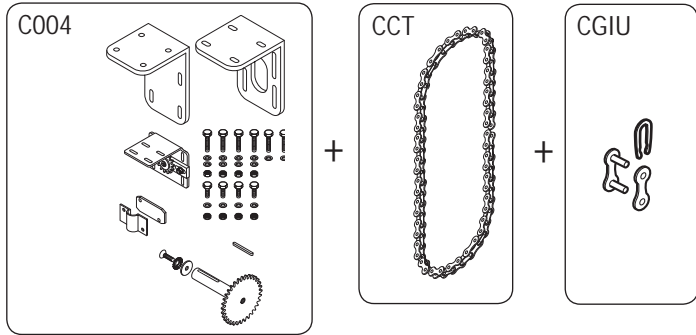

1) Before securing the ratiomotor, open the protection cover to facilitate post-assembly operations.

2) Assemble the two fixing brackets and secure them to the ratiomotor.

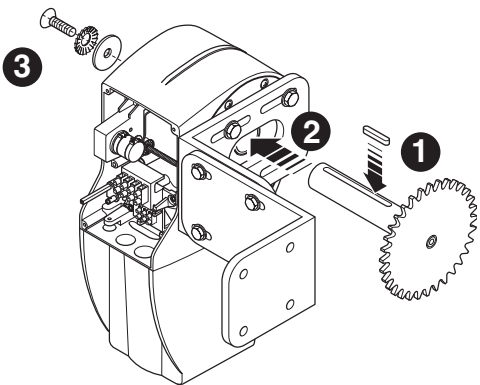
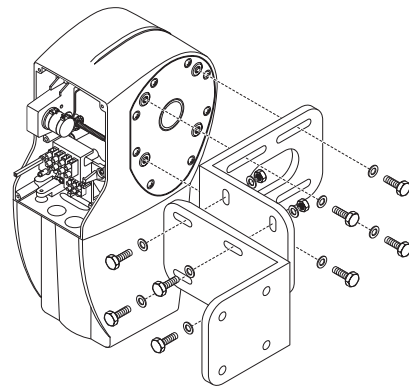

3) Insert the tongue into the cavity of the toothed pinion's shaft Z26, insert the pinion into the motor cable shaft and secure it with a screw (UNI 5933 M6x16) and washer from the opposite side.

4) Secure the assembly with suitable elements, chosen according to the shape of the wall.

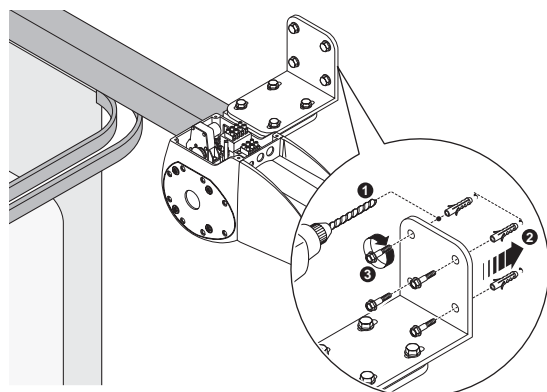

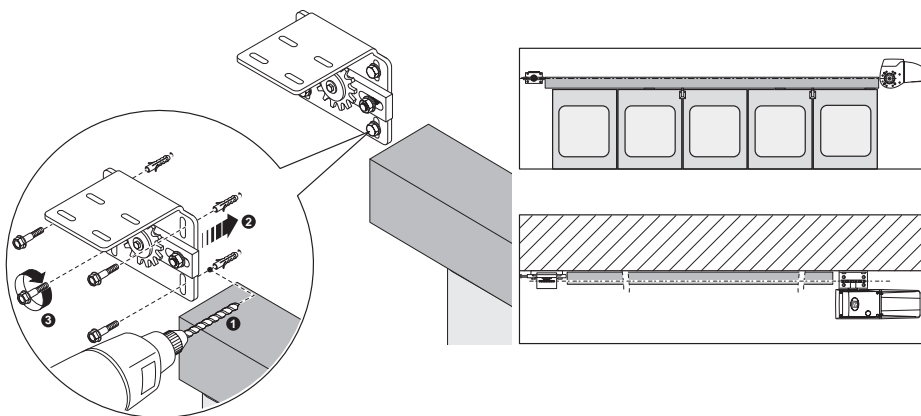

5) Secure the chain-tensioning transmission from the opposite side of the ratiomotor in line with the pinion.

6) Insert the 1/2 inch chain (CCT) with a length of twice distance A.

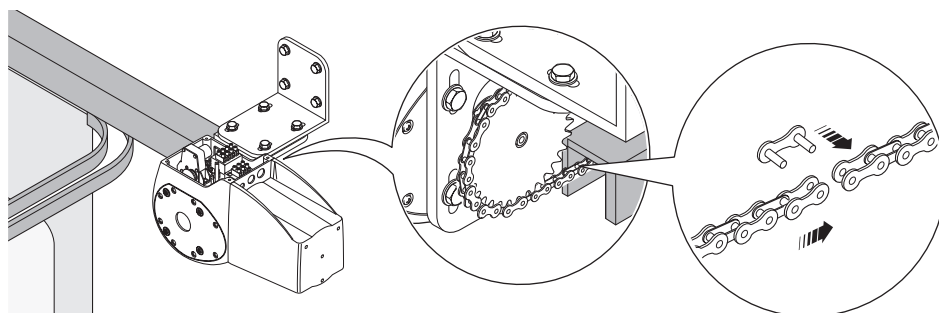
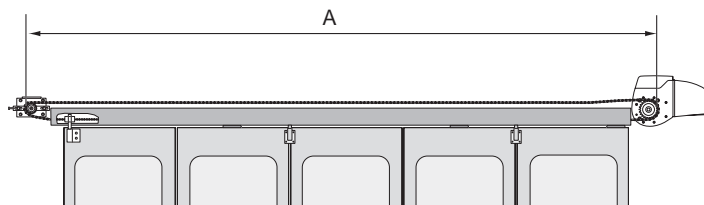

7) Unite the two ends with a coupling (CGIU).

8) Adjust the chain's tension with the transmission's screw and then tighten the nuts.

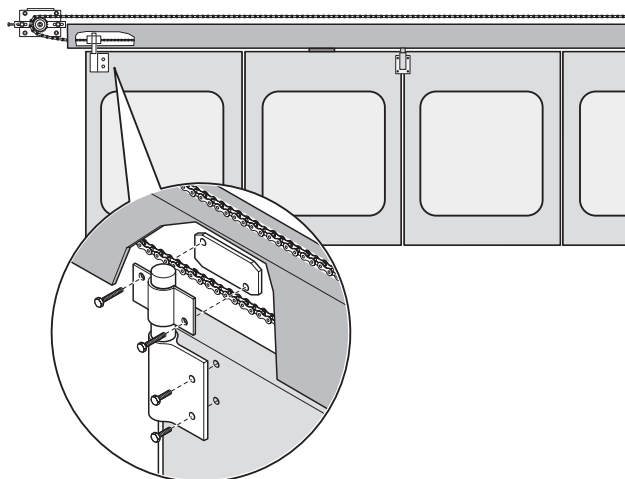
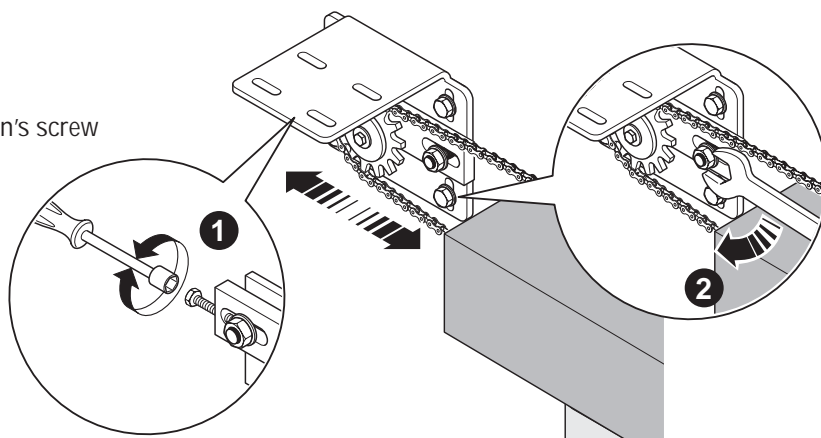

9) Secure the chain to the pivot of the first wing with the chain hitch bracket and screws UNI 5931 M8x30.

All the data and information contained herein is considered subject to change at any time and at our discretion

5.6 Wiring gearmotors with an encoder system to the command board

For the wiring, use appropriate sheaths and cable clamps to ensure the right degree of protection. To regulate the encoder, make reference to the technical manual of the command board.

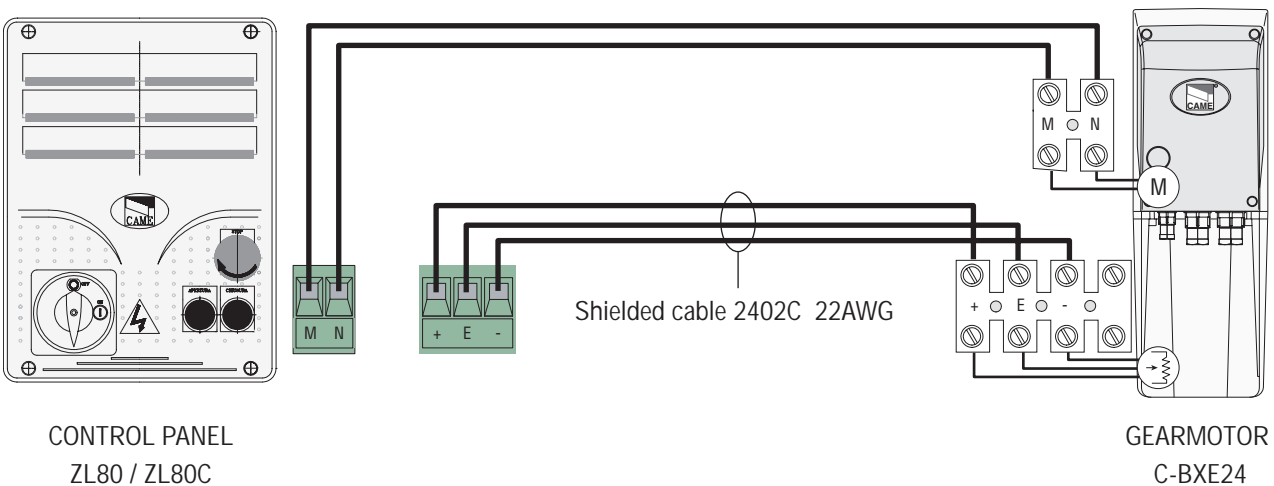
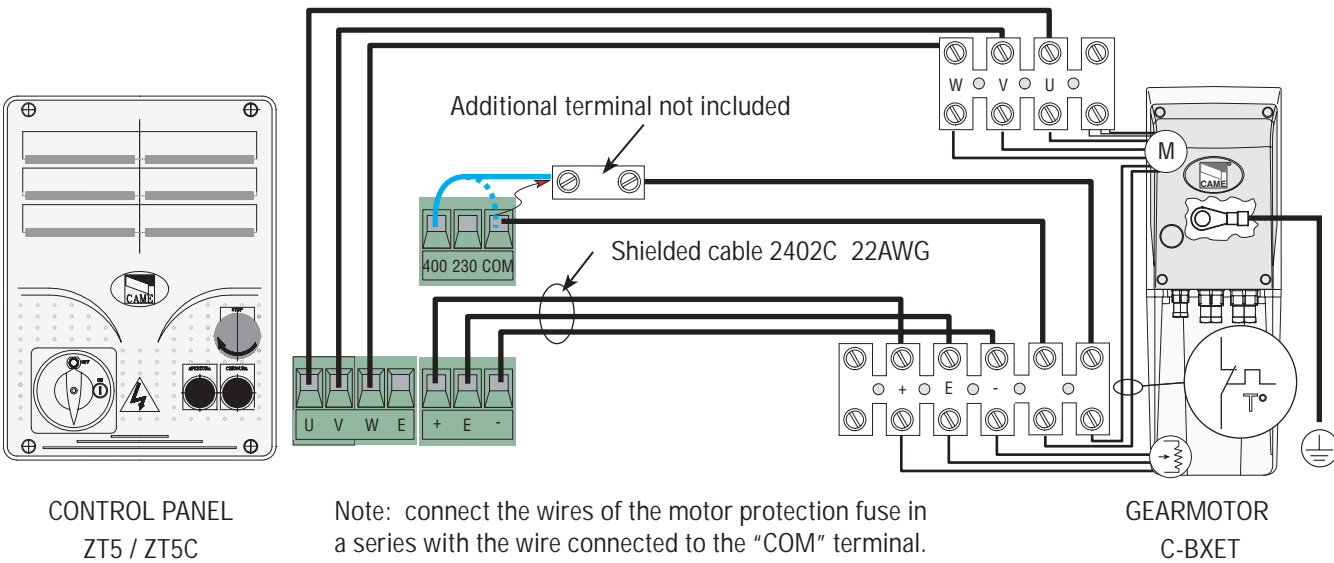
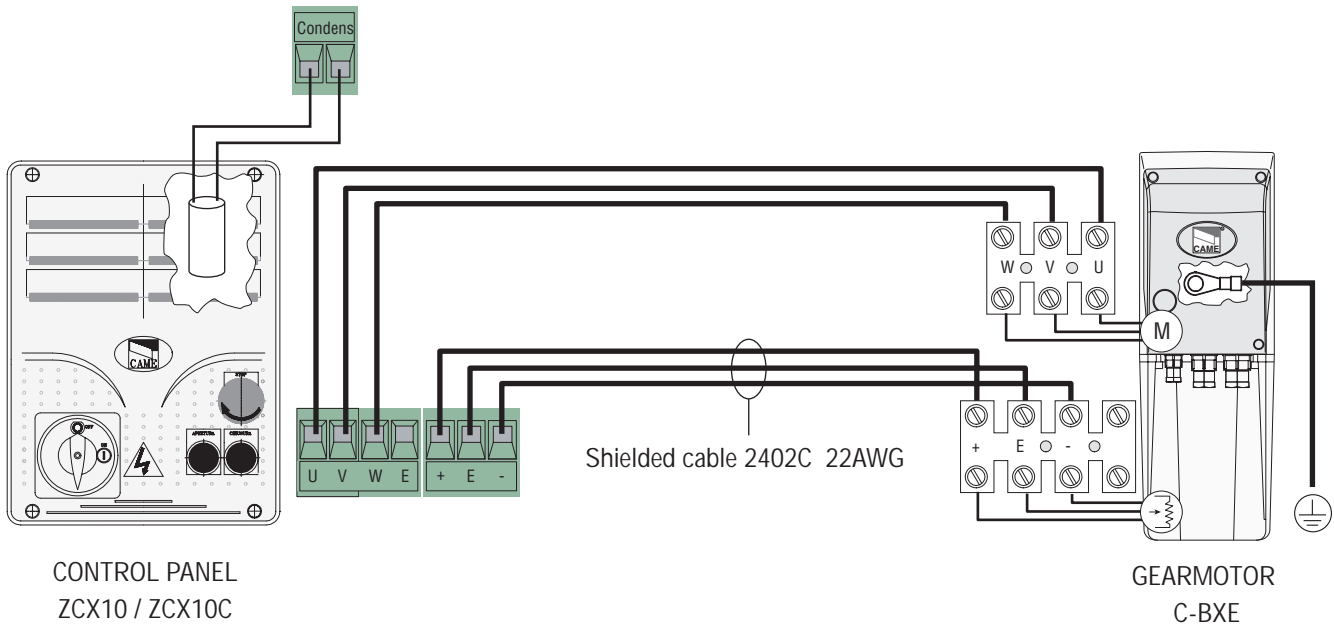

All the data and information contained herein is considered subject to change at any time and at our discretion

5.7 Wiring gearmotors with mechanical end-stops to the command board

For the wiring, use appropriate sheaths and cable clamps to ensure the right degree of protection.

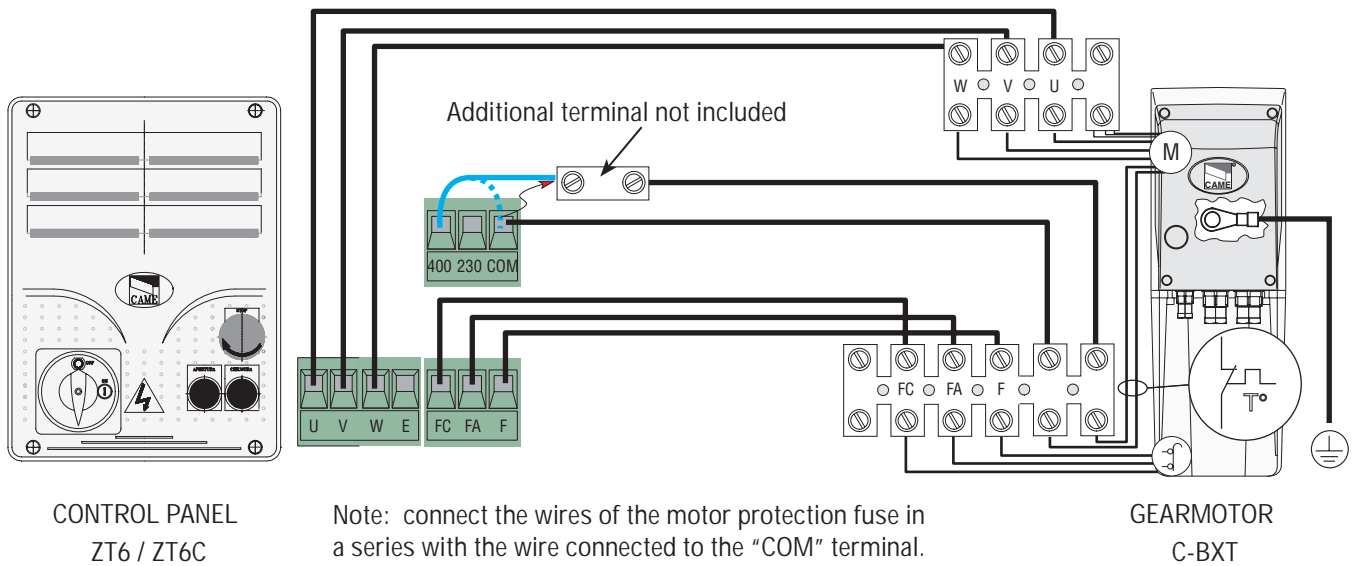
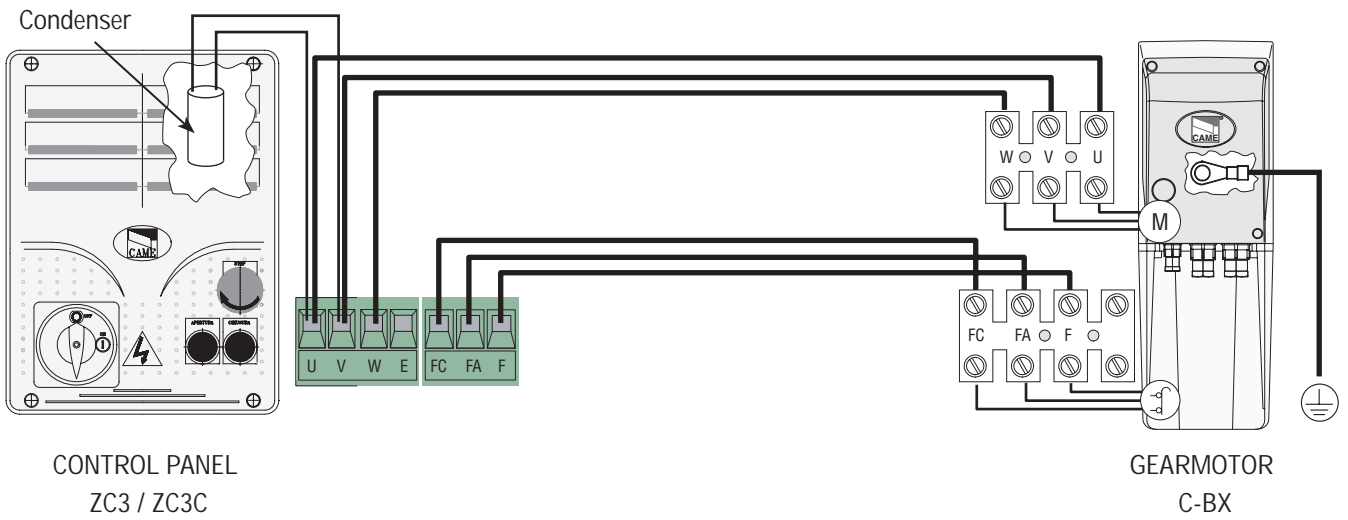

5.8 Direct connection by interlocking buttons only for C-BX gearmotor

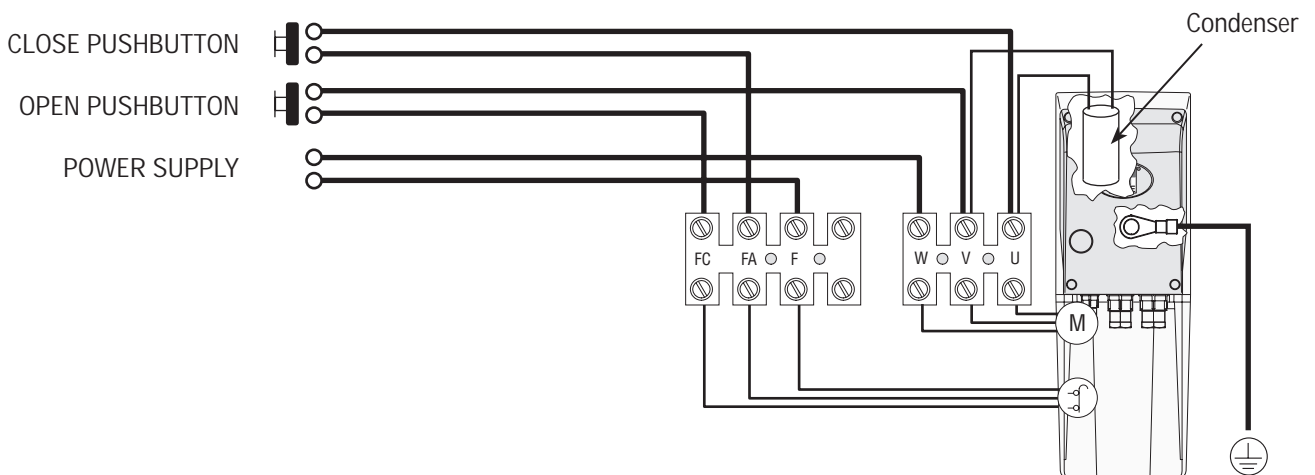

5.9 Adjusting mechanical end-stops

Make sure the door is in a closed position and the two crown wheels of the motor units are both positioned to the left.

N.B.: the gearmotor is already adjusted in a closed position, namely, the closing end-stop micro-switch is activated.

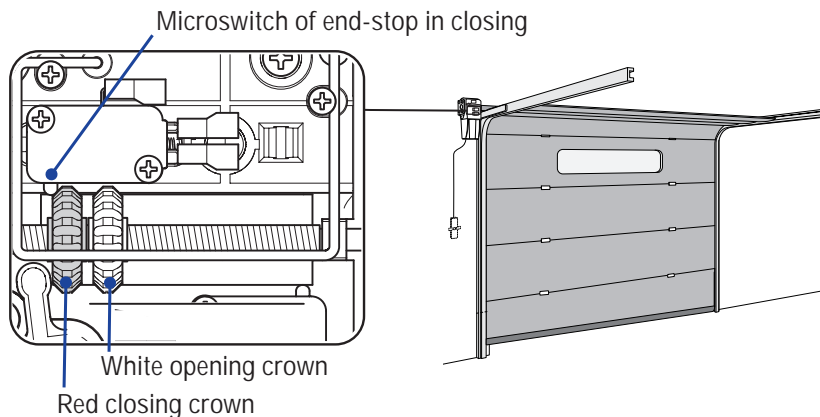

Execute a complete opening run manually or by using the button on the command board; the two crowns will move to the right.

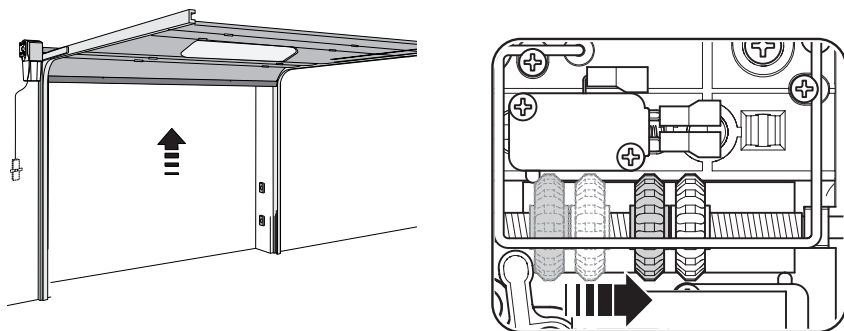

Using a screwdriver, raise the end-stop spring from the crown wheels; manually move the white crown until it reaches the opening microswitch and then lower the spring onto the crowns.

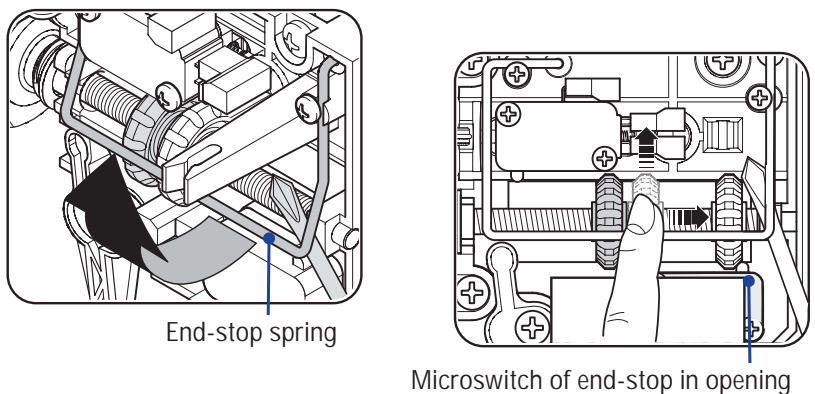

Make a complete closing run and ensure that the release lever is free from the safety lever.

NB: the safety lever releases the emergency release (CMS or C002) only when the door is closed.

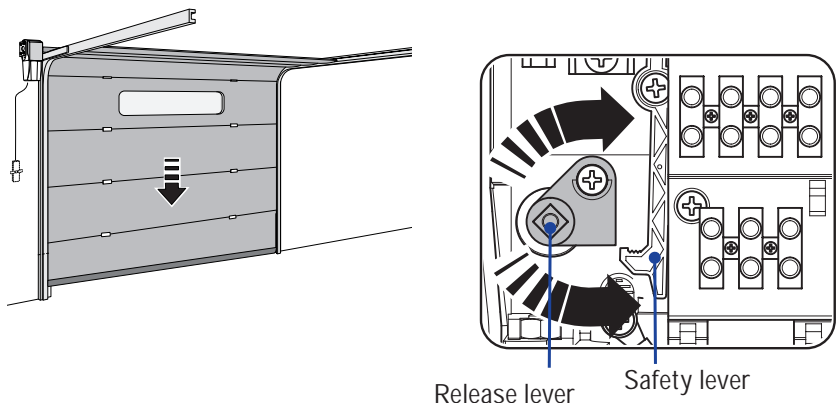

Warning! After making the adjustments on sectional doors in a closed position, there may be a gap between the lower edge of the door and the ground surface. To eliminate this gap, move the micrometric lever one step up or down to lower or raise the door by one centimetre.

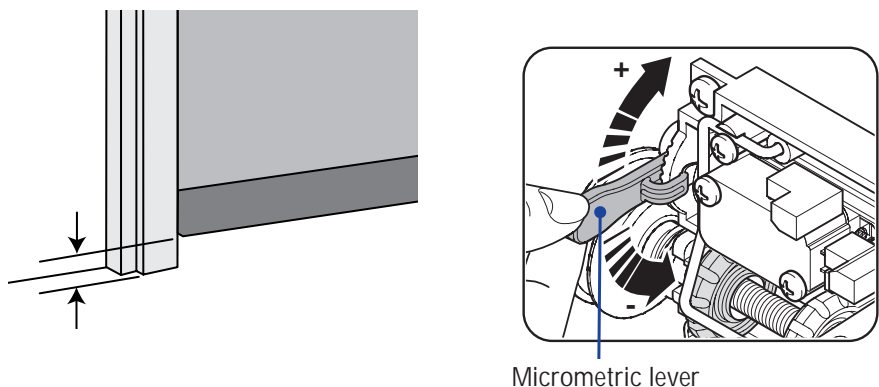

All the data and information contained herein is considered subject to change at any time and at our discretion

Important! For garmotors installed on sliding and folding doors, remove the security lever and respective spring.

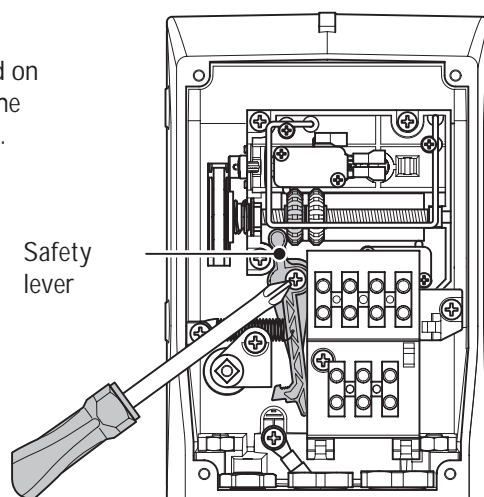

5.10 Adjusting end-stops with encoder

Before beginning to make adjustments on the end-stop, execute the **run calibration** procedure described in the technical manual of the command board.

After calibrating, the door must be in a closed position and the crown wheel on the motor unit must be positioned to the left.

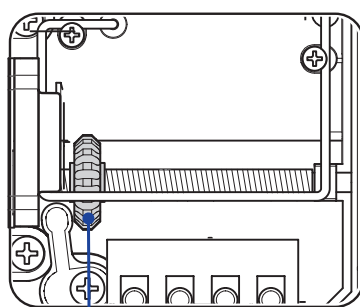

Crown wheel

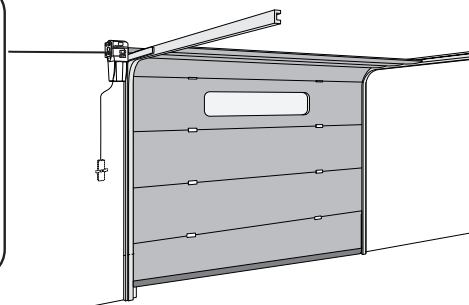

Raise the end-stop spring unhooking it from the support bracket and lower it onto the crown wheel.

Important! For garmotors installed on sliding and folding doors, never unhook the end-stop spring from the support bracket.

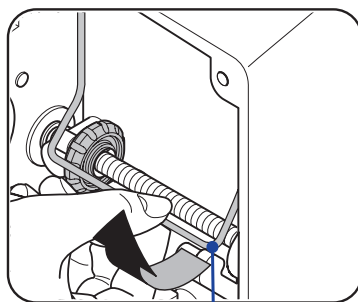

End-stop spring

Support bracket

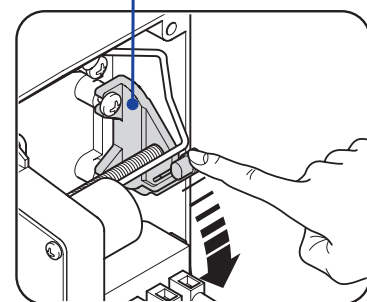

Ensure that the release lever is free from the safety lever.

NB: the safety lever releases the emergency release (CMS or C002) only with the door closed.

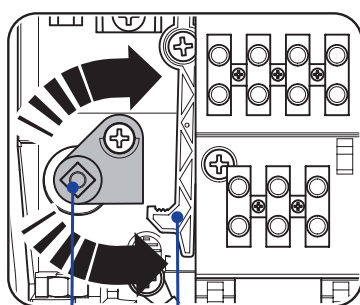

Release lever

Safety lever

5.11 Assembly cover

1) After completing assembly and electrical connections, make a hole with a Ø 13 mm bit in the cover in the point indicated.

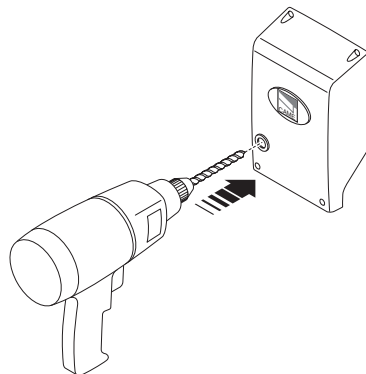

2) Anchor the cover with the four screws provided.

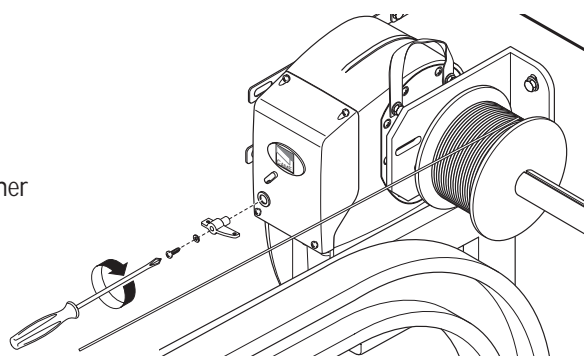
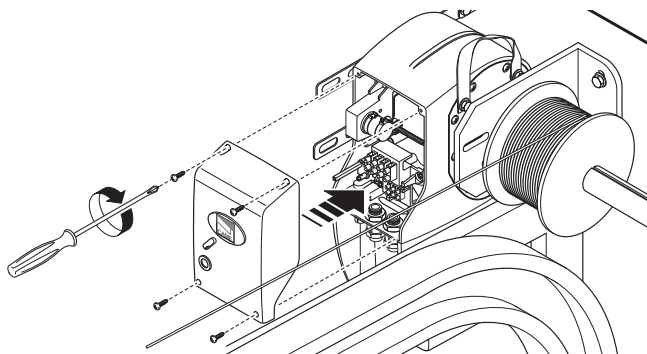

3) Insert the release handle into the hole and fasten it with the washer and the screw.

5.12 Manual actuating device

Manually-operated winch for sectional doors (optional).
A chain-operated device for opening and closing the sectional door, it can be used both when the automation is either horizontal or vertical.

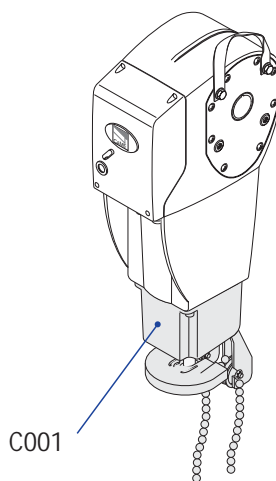

5.13 Emergency release

Devices for releasing the ratiomotor by personalised wrench (CMS) or with lever complete with suspended-cord transmission (C002).

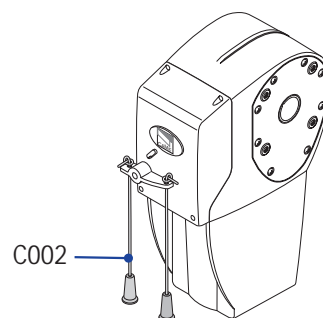
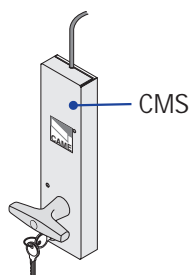

All the data and information contained herein is considered subject to change at any time and at our discretion

6 Maintenance

 This unit requires no specific maintenance. Only as a precautionary measure and in the case of intensive use is it recommended that you periodically check (6 months) the electric cable connected to the motor, the chain tension, and the bolts and screws; you can also grease the sliding points between the fixed and mobile parts.

All checks must be recorded (in a dedicated record-book).

7 Demolition and disposal

 In its premises, CAME CANCELLI AUTOMATICI S.p.A. implements an Environmental Management System certified in compliance with the UNI EN ISO 14001 standard to ensure environmental protection.

Please continue our efforts to protect the environment—which CAME considers one of the cardinal elements in the development of its operational and market strategies—simply by observing brief recommendations as regards disposal:

 **DISPOSAL OF PACKAGING** – The packaging components (cardboard, plastic, etc.) are all classifiable as solid urban waste products and may be disposed of easily, keeping in mind recycling possibilities.

Prior to disposal, it is always advisable to check specific regulations in force in the place of installation.

PLEASE DISPOSE OF PROPERLY!

 **PRODUCT DISPOSAL** – Our products are made up of various types of materials. Most of them (aluminium, plastics, iron, electrical wires, etc.) may be disposed of in normal garbage collection bins and can be recycled by disposing of in specific recyclable material collection bins and disposal in authorized centres. Other components (electrical boards, remote control batteries, etc.), however, may contain polluting substances. They should therefore be removed and given to qualified service companies for proper disposal.

Prior to disposal, it is always advisable to check specific regulations in force in the place of disposal.

PLEASE DISPOSE OF PROPERLY!

8 Manufacturer's warranty



MANUFACTURER'S DECLARATION

As per Enclosure II B of Machinery Directive 98/37/CE

Enclosed with the technical documentation (the original copy of the Declaration is available on request)

Date of the present declaration 07/12/2001

The representatives of

CAME Cancelli Automatici S.p.A.
via Martiri della Libertà, 15
31030Dossan di Casier - Treviso - ITALYtel
(+39) 0422 4940 - fax (+39) 0422 4941
internet: www.came.it - e-mail: info@came.it

Hereby declare, under their own responsibility, that the product/s called ...

CBX - CBXE - CBXE24 - CBXT - CBXET

**CMS - CGP - CCT - CGIU - C001 - C002 - C003
C004 - C005 - C006 - C007 - C008**

... comply with the Italian National Legal Provisions that transpose the following Community Directives (where specifically applicable):

MACHINERY DIRECTIVE 98/37/CE
LOW VOLTAGE DIRECTIVE 73/23/EEC - 93/68/EEC
ELECTROMAGNETIC COMPATIBILITY DIRECTIVE 89/336/EEC - 92/31/EEC
R&TTE DIRECTIVE 1999/5/CE

Also, they furthermore represent and warrant that the product/s that are the subject of the present Declaration are manufactured in the respect of the following main harmonized provisions:

EN 292 PART 1 AND 2	MACHINERY SAFETY.
EN 12453	INDUSTRIAL, COMMERCIAL AND OTHER CLOSING MECHANISMS.
EN 12445	INDUSTRIAL, COMMERCIAL AND OTHER CLOSING MECHANISMS.
EN 12978	SAFETY DEVICES FOR POWER OPERATED DOORS AND GATES
EN 60335 - 1	SAFETY IN APPARATUS FOR HOME USE.
EN 60204 - 1	MACHINERY SAFETY.
EN 61000 - 6 - 2	ELECTROMAGNETIC COMPATIBILITY.
EN 61000 - 4 - 4	ELECTROMAGNETIC COMPATIBILITY.
EN 61000 - 4 - 5	ELECTROMAGNETIC COMPATIBILITY.

IMPORTANT CAUTION!

It is forbidden to market/use product/s that are the subject of this declaration before completing and/or incorporating them in total compliance with the provisions of Machinery Directive 98/37/CE

Signatures of the Representatives

TECHNICAL MANAGER
Mr. Gianni Michielan

MANAGING DIRECTOR
Mr. Paolo Menuzzo

All the data and information contained herein is considered subject to change at any time and at our discretion

CAME UNITED KINGDOM LTD
UNIT 3, ORCHARD BUSINESS PARK TOWN
STREET, SANDIACRE
NOTTINGHAM - NG10 5BP - U.K.
Tel 0044 115 9210430
Fax 0044 115 9210431

